



# Tyrrell & Laing International Inc.

## BATHTUBS

### TECHNICAL SPECIFICATIONS

CSI Division 06600; 06610; 224223

\*\*All products made of MasterCast Engineered Composites\*\*

LAST REVISED: 10/18/2011

## Linnia Free Standing Tub

**Approximate Cast Weight:** 312 lbs (141 kg)

**Est. Water Capacity:** 63.4 gal (240 litres)



### USES:

Std tub with deck:	NO
Undermount:	YES
Drop-in:	YES
Free standing:	YES

### Included Features:

- Fire retardant
- Solid one-piece construction
- Pre-sloped to drain
- Mold and mildew resistant
- Bacteria resistant
- Non-porous
- Stain resistant and easy to clean
- Waterproof and leakproof

*Our products comply with one or more of the following: IAPMO, ANSI, HUD, NAHB, NHQ*

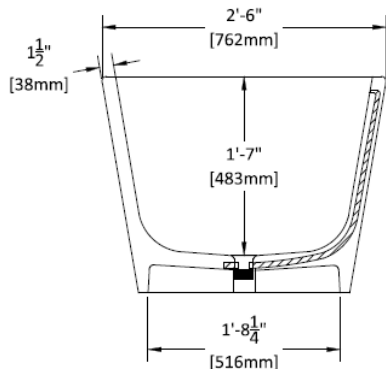
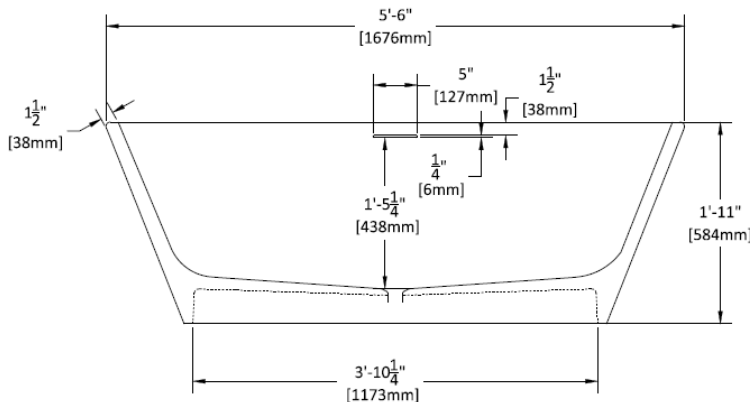
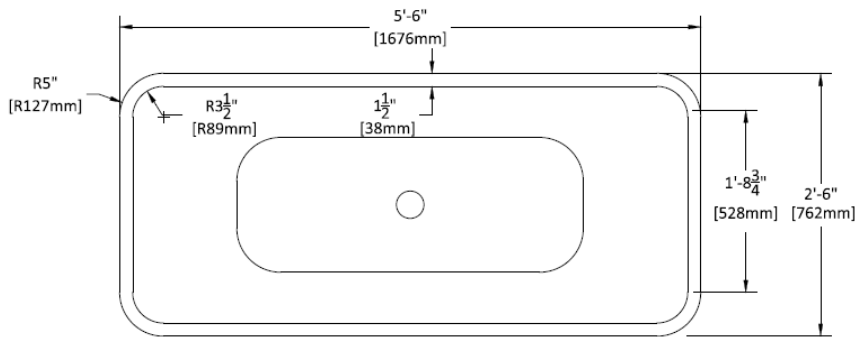

### Drain Details:

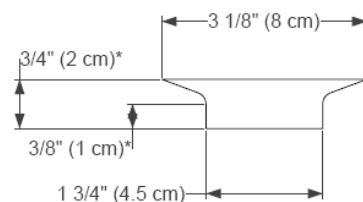

\* dimensions may vary slightly